

NOTES:
 1) IF MOTOR EXHIBITS POSITIVE FEEDBACK, SWITCH ENCODER A,B WIRES
 2) KEEP ENCODER / INPUTS AWAY FROM NOISEY MOTOR POWER WIRES.

NOTE: ENCODER SIGNALS MUST BE >4.5V HIGH LEVEL.
 THIS MAY REQUIRE EXTERNAL PULLUPS.

SEE PAGE 2 FOR BRUSH MOTOR WIRING
 SEE PAGE 3 FOR MANUFACTURER
 SPECIFIC BLDC MOTOR WIRING EXAMPLES

EZ SERVO WIRING DIAGRAM		Rev A12	AllMotion 30097 Ahern Ave Union City CA, 94587 United States Office: 510-471-4000 Fax: 510-400-8001
EZSV17WW BLDC MOTOR WIRING			
Date Created: 05/29/2016	Date Revised: 06/09/2022	Print Date: 6/9/2022 1:47:56 PM	Sheet Size: 11" x 17"
Page 1	of 5		



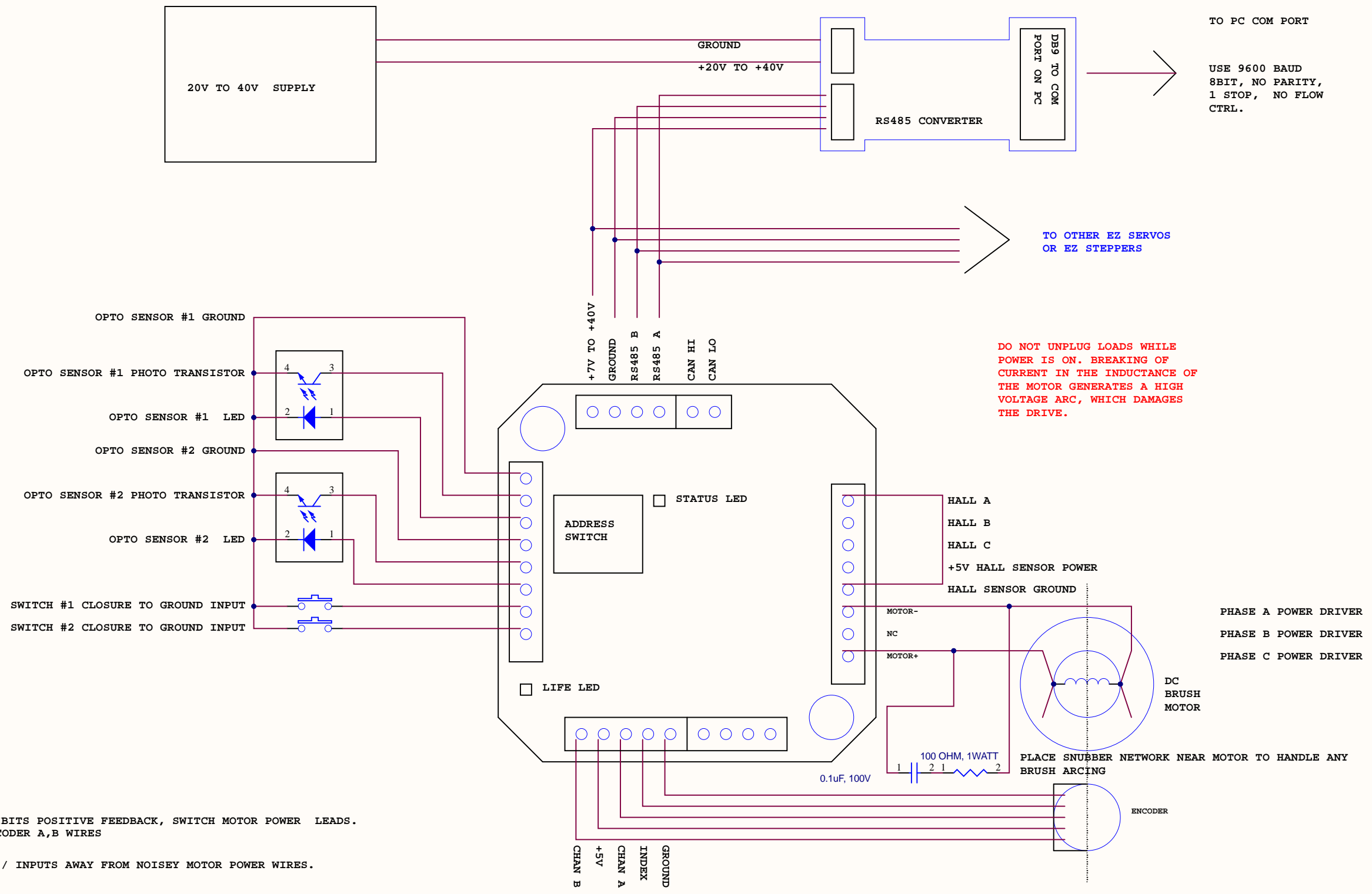

TO PC COM PORT
 USE 9600 BAUD
 8BIT, NO PARITY,
 1 STOP, NO FLOW
 CTRL.

TO OTHER EZ SERVOS
 OR EZ STEPPERS

DO NOT UNPLUG LOADS WHILE
 POWER IS ON. BREAKING OF
 CURRENT IN THE INDUCTANCE OF
 THE MOTOR GENERATES A HIGH
 VOLTAGE ARC, WHICH DAMAGES
 THE DRIVE.

PHASE A POWER DRIVER
 PHASE B POWER DRIVER
 PHASE C POWER DRIVER

PLACE SNUBBER NETWORK NEAR MOTOR TO HANDLE ANY
 BRUSH ARCING

NOTE: ENCODER SIGNALS MUST BE >4.5V HIGH LEVEL.
 THIS MAY REQUIRE EXTERNAL PULLUPS.

- NOTES:
- 1) IF MOTOR EXHIBITS POSITIVE FEEDBACK, SWITCH MOTOR POWER LEADS. OR SWITCH ENCODER A,B WIRES
 - 2) KEEP ENCODER / INPUTS AWAY FROM NOISEY MOTOR POWER WIRES.

SEE PAGE 1 FOR BRUSHLESS MOTOR WIRING
 SEE PAGE 3 FOR MANUFACTURER SPECIFIC
 BLDC MOTOR WIRING EXAMPLES

EZ SERVO WIRING DIAGRAM		Rev A12	AllMotion 30097 Ahern Ave Union City CA, 94587 United States Office: 510-471-4000 Fax: 510-400-8001
EZSV17WV BRUSH MOTOR WIRING			
Date Created: 05/29/2016	Date Revised: 06/09/2022	Print Date: 6/9/2022 1:47:56 PM	Page 2 of 5
COPYRIGHT ALLMOTION.COM		Sheet Size: 11" x 17"	



SIZE: 1.6" X 1.6" x 0.6" THICK

POWER INPUT AND COMMUNICATION

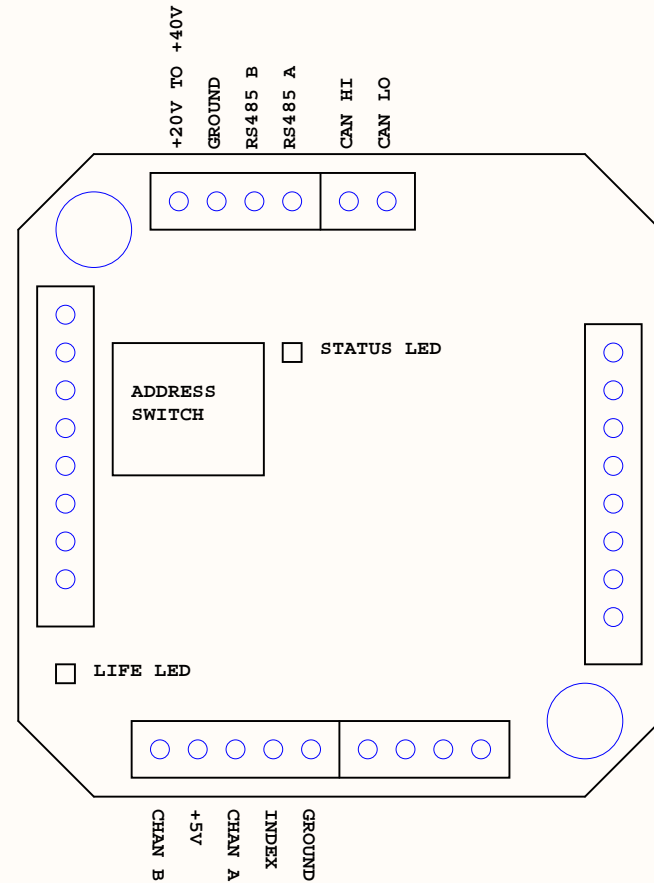

ENCODER CONNECTION

NOTE: ENCODER SIGNALS MUST BE >4.5V HIGH LEVEL.
THIS MAY REQUIRE EXTERNAL PULLUPS.

POPULAR MANUFACTURER WIRE COLORS

MOTOR CONNECTION	PITTMAN	MAXON	EAD OPTICAL HALL	EAD MAGNETIC HALL	FAULHARBER	ANAHEIM AUTOMATI	HARMONIC DRIVES RSF8B	PORTESCAP NUVODISC 32BF	MAXON EC-max
HALL A	WHITE	BLUE		BROWN	YELLOW	GREEN	WHITE	YELLOW	GREY
HALL B	GREY	GREY		WHITE	GREEN	BLUE	BLUE	BROWN	BROWN
HALL C	BLUE	VIOLET		GREEN	GREY	GREY	GREEN	RED	YELLOW
+5V HALL SENSOR POWER	PURPLE	YELLOW	NC		ORANGE	RED	RED	WHITE (PINK)	GREEN
HALL SENSOR GROUND	BLACK	GREEN	NC		BLACK	BLACK	BLACK	BLACK	BLUE
PHASE A POWER DRIVER	BROWN	ORANGE	BROWN		BROWN	BROWN	BLACK (M)	BLACK (M)	BLACK
PHASE B POWER DRIVER	RED	RED	WHITE		WHITE	ORANGE	YELLOW (M)	RED (M)	RED
PHASE C POWER DRIVER	ORANGE	BROWN	BLUE		BLUE	YELLOW	RED (M)	WHITE (M)	WHITE

FROM OPTICAL ENCODER + HALL

GROUND BLACK
INDEX ORANGE
CHAN A YELLOW
+5V RED
CHAN B BLUE

DO NOT CONNECT ORANGE BLUE GREEN

PLEASE NOTE: FOR OTHER MOTORS, ALLMOTION WILL BE PLEASED TO WORK OUT THE WIRING FOR NO CHARGE.

EZ SERVO WIRING DIAGRAM		Rev A12	AllMotion 30097 Ahern Ave Union City CA, 94587 United States Office: 510-471-4000 Fax: 510-400-8001
EZSV17WV WIRE COLOR CODE EXAMPLES			
Date Created: 05/29/2016	Date Revised: 06/09/2022	Print Date: 6/9/2022 1:47:56 PM	Sheet Size: 11" x 17"
Page 3	of 5		



EZSV17 ACESSORIES AND OTHER ELECTRICAL NOTES

MATING CONNECTORS:

AMP MTA 100 SERIES

- 2PIN 26 AWG DIGIKEY P/N A31024-ND (CAN CONNECTOR)
- 4PIN 22 AWG DIGIKEY P/N A31108-ND (INPUT CONNECTOR)
- 8PIN 22 AWG DIGIKEY P/N A31111-ND (NEMA23 MOTOR)
- 8PIN 24 AWG DIGIKEY P/N A23820-ND (NEMA17 MOTOR)
- 8PIN 26 AWG DIGIKEY P/N A31030-ND (FOR OPTOS)
- 5PIN 26 AWG DIGIKEY P/N A31027-ND (FOR ENCODER)
- T HANDLE CRIMP TOOL DIGIKEY P/N A9982-ND

MOTORS:

- 1) THE EZ SERVO WILL DRIVE MOST SERVO MOTORS
- 2) FOR BEST PERFORMANCE SELECT A MOTOR THAT HAS A BACK EMF OF ABOUT 1/2 OF THE SUPPLY VOLTAGE, AT THE MAX SPEED DESIRED TO RUN AT. (Eg USE A 12V MOTOR WITH A 24V SUPPLY).
- 3) TYPICALLY A MOTOR THAT HAS AN INDUCTANCE OF AROUND 1mH AND A RESISTANCE OF AROUND 1 OHM WORKS WELL. BUT OTHER VALUES ARE ALSO OK. (0.5mH MINIMUM)

ENCODERLESS OPERATION:

- 1) THE EZSERVO CAN PERFORM VELOCITY MODE CONTROL OF A MOTOR THAT DOES NOT HAVE AN ENCODER BY USING THE HALL SENSORS AS A GAGE OF SPEED. (N=0 MODE)
- 2) IT IS POSSIBLE TO USE THE N=1 POSITION CONTROL MODE BY WIRING TWO OF THE HALL SENSOR LINES TO THE ENCODER A AND B INPUTS IN ADDITION. THIS ALLOWS A CRUDE POSITION CONTROL MODE. IN THIS MODE THE VELOCITY CONTROL IS SUPERIOR TO THE N=0 MODE. USE SMALL ACCELEARTIONS AND VELOCITIES IN THIS MODE. Eg TRY /1L1V10000P0R
- 3) IF WIRING HALL SENSORS AS ENCODERS , USE THE ENCODER 5 V TO POWER THE HALL SENSORS.

OPTO HOME SWITCH:

- 1) "Z" OR HOME COMMAND RUNS MOTOR UNTIL OPTO #1 IS ON FLAG EDGE.
- 2) AN OPTO SWITCH PROVIDED WITH EACH STARTER KIT
- 3) USE TRANSISTOR OPTO THAT HAS $I_c > 1mA$ @ $I_F = 20mA$.
- 4) EXAMPLES OF ACCEPTABLE OPTOS ARE:
 - DIGIKEY P/N QVA11134-ND
 - DIGIKEY P/N H21A1IS-ND
 - HONEYWELL HOA1887-012 (IS PREWIRED)
 - HONEYWELL HOA1870-033 (IS PREWIRED)
 - OPTEK OPB830W11 (IS PREWIRED)
- 5) THE OPTO COUPLER LED PIN HAS 200 OHM TO 5V IN SERIES ON THE BOARD. THE 200 OHM CAN BE REMOVED IF DESIRED FOR RUNNING SENSORS THAT REQUIRE DIRECT ACESS TO 5V. (OR USE ENCODER 5V POWER) THE COLLECTOR OF THE TRANSISTOR HAS A 10K PULLUP TO 5V.
- 6) ALL INPUTS WORK ON TTL LEVEL SIGNALS

EZ SERVO WIRING DIAGRAM

EZSV17WV

ACCESSORY & ELECTRICAL NOTES

Rev
A12

Date Created: 05/29/2016

Date Revised: 06/09/2022

Print Date: 6/9/2022

1:47:56 PM

Page

4

of

5

Sheet Size: 11" x 17"

AllMotion
30097 Ahern Ave
Union City CA, 94587
United States

Office: 510-471-4000
Fax: 510-400-8001



FEEDBACK POT1 GROUND
 FEEDBACK POT1 WIPER
 FEEDBACK POT1 POWER

POSITION COMMAND POT2 GROUND
 POSITION COMMAND POT2 WIPER
 POSITION COMMAND POT2 POWER

SWITCH #1 CLOSURE TO GROUND INPUT
 SWITCH #2 CLOSURE TO GROUND INPUT

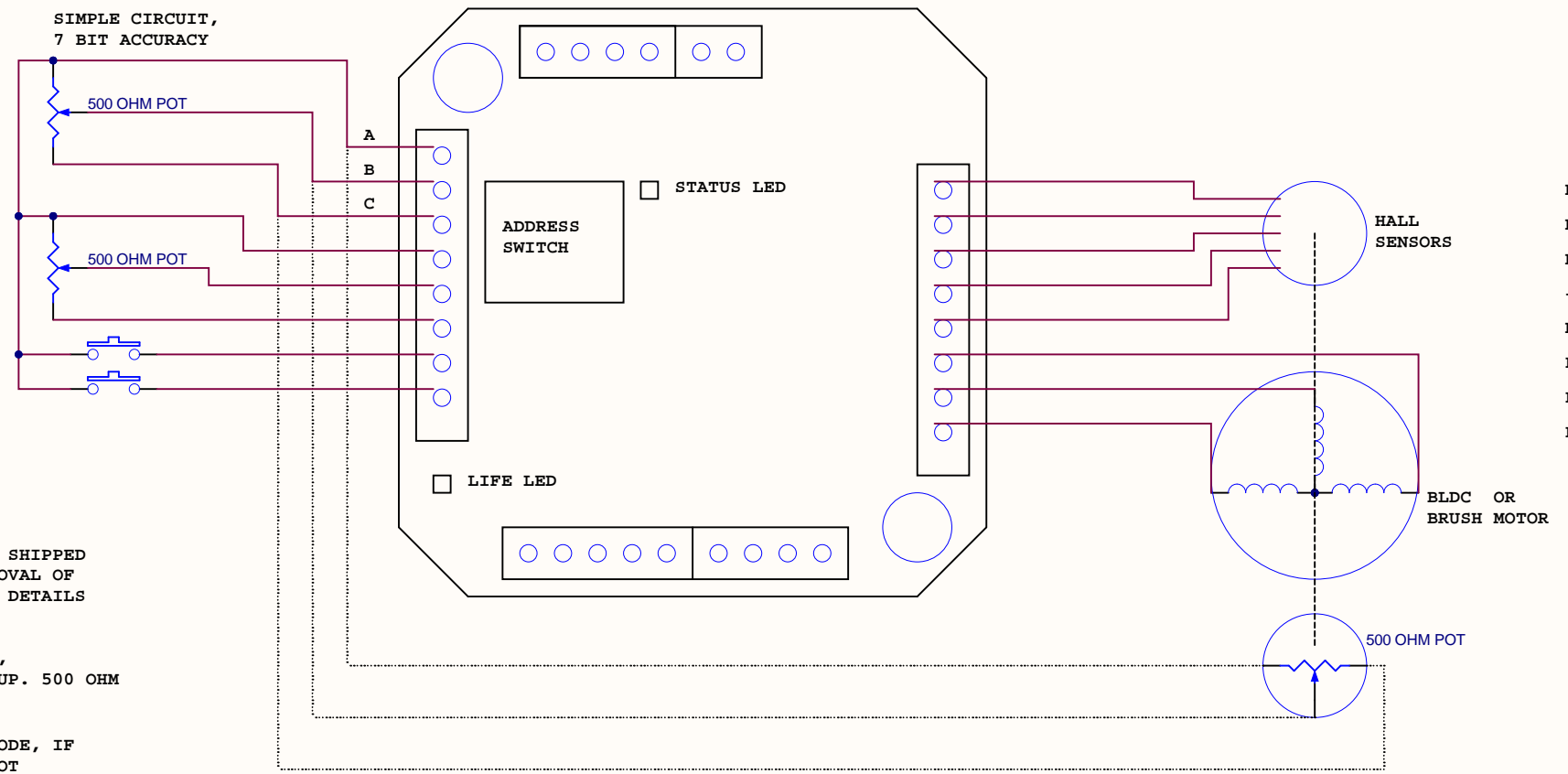

HALL A
 HALL B
 HALL C
 +5V HALL SENSOR POWER
 HALL SENSOR GROUND
 PHASE A POWER DRIVER
 PHASE B POWER DRIVER
 PHASE C POWER DRIVER

NOTES:

- 1) ALL 4 INPUTS ARE ANALOG INPUTS
- 2) ADC's VALUES RANGE FROM 0-16368. THE ACCURACY AS SHIPPED IS 7 BIT BUT CAN BE IMPROVED TO >10BIT WITH THE REMOVAL OF THE INPUT PROTECTION CIRCUITRY, CONTACT FACTORY FOR DETAILS
- 3) POTS IN THE RANGE OF 500 OHM - 10K ARE SUGGESTED, LOWER VALUES ARE LESS AFFECTED BY INTERNAL 10K PULLUP. 500 OHM RECOMMENDED.
- 4) IF USING POT FOR POSITION FEED BACK WITH /1N3R MODE, IF MOTOR EXHIBITS POSITIVE FEEDBACK, SWITCH ENDS OF POT
- 5) 10K INTERNAL PULLUP WILL INTERFERE WITH LINEARITY OF POT VOLTAGE, AND MAY NEED TO BE REMOVED - CONTACT FACTORY.
- 6) INPUT OVERVOLTAGE PROTECTION CIRCUITRY MAY NEED TO BE REMOVED FOR >7BIT ACCURACY - CONTACT FACTORY.

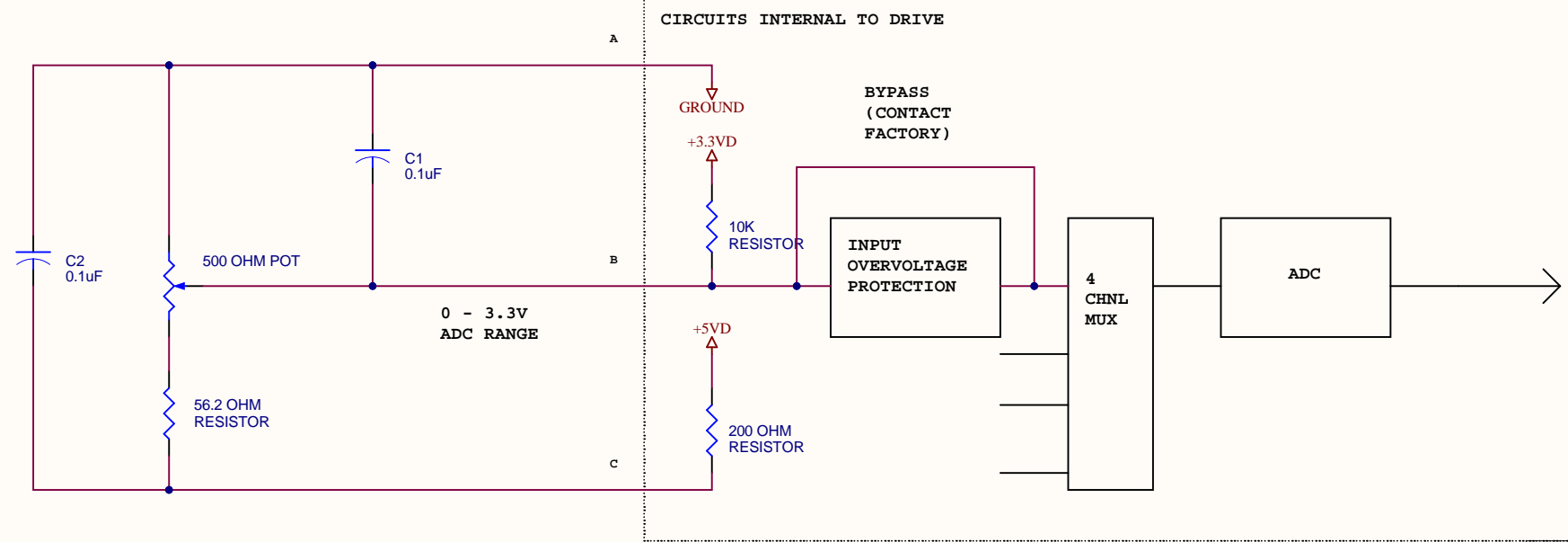

ENHANCED EXTERNAL CIRCUIT FOR > 10BIT ACCURACY

EZ SERVO WIRING DIAGRAM		Rev A12	AllMotion 30097 Ahern Ave Union City CA, 94587 United States Office: 510-471-4000 Fax: 510-400-8001
EZSV17WW			
ANALOG INPUT OR POTENTIOMETER FEEDBACK			
Date Created: 05/29/2016			
Date Revised: 06/09/2022			
Print Date: 6/9/2022 1:47:56 PM		Page 5 of 5	Sheet Size: 11" x 17"