

EZCTRL17 MODES

MODE1: I/O CONTROLLER
 MODE2: 4 AXIS STEPPER CONTROLLER
 MODE3: 2 AXIS SERVO CONTROLLER
 MODE4: 4 AXIS TEMPERATURE CONTROLLER
 MODE3: 3 AXIS RC SERVO CONTROLLER

POWER AND
 RS485 / CAN
 COMMUNICATIONS
 INPUT

PRELIMINARY

I/O MODE: 3 ANALOG INPUTS / 2 OUTPUTS
 4 AXIS CONTROLLER MODE: STEP AND DIR OUTPUT AXIS #1
 SERVO CONTROLLER MODE: 3 INPUTS / 2 OUTPUTS

INPUT
 CONNECTOR
 4
 ANALOG
 INPUTS

ENCODER
 INPUT

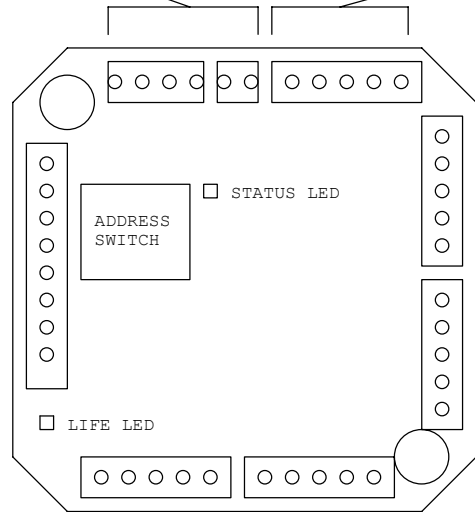

I/O MODE: 3 ANALOG INPUTS / 2 OUTPUTS
 4 AXIS CONTROLLER MODE: STEP AND DIR OUTPUT AXIS #2
 SERVO CONTROLLER MODE: +/- 10V OUTPUT SERVO AXIS #1

I/O MODE: 3 ANALOG INPUTS / 2 OUTPUTS
 4 AXIS CONTROLLER MODE: STEP AND DIR OUTPUT AXIS #3
 SERVO CONTROLLER MODE: +/- 10V OUTPUT SERVO AXIS #2

I/O MODE: 3 ANALOG INPUTS / 2 OUTPUTS
 4 AXIS CONTROLLER MODE: STEP AND DIR OUTPUT AXIS #4
 SERVO CONTROLLER MODE: 3 INPUTS / 2 OUTPUTS

ENCODER
 INPUT

| | | |
|--|-----------------------------|--------------|
| Title | | |
| ALLMOTION.COM EZ CONTROLLER WIRING DIAGRAM | | |
| Size | Document Number | Rev |
| B | EZ CTRL WIRING | B6 |
| Date: | Saturday, December 13, 2008 | Sheet 1 of 7 |

EZCTRL17 WIRED AS 4 AXIS CONTROLLER

PRELIMINARY

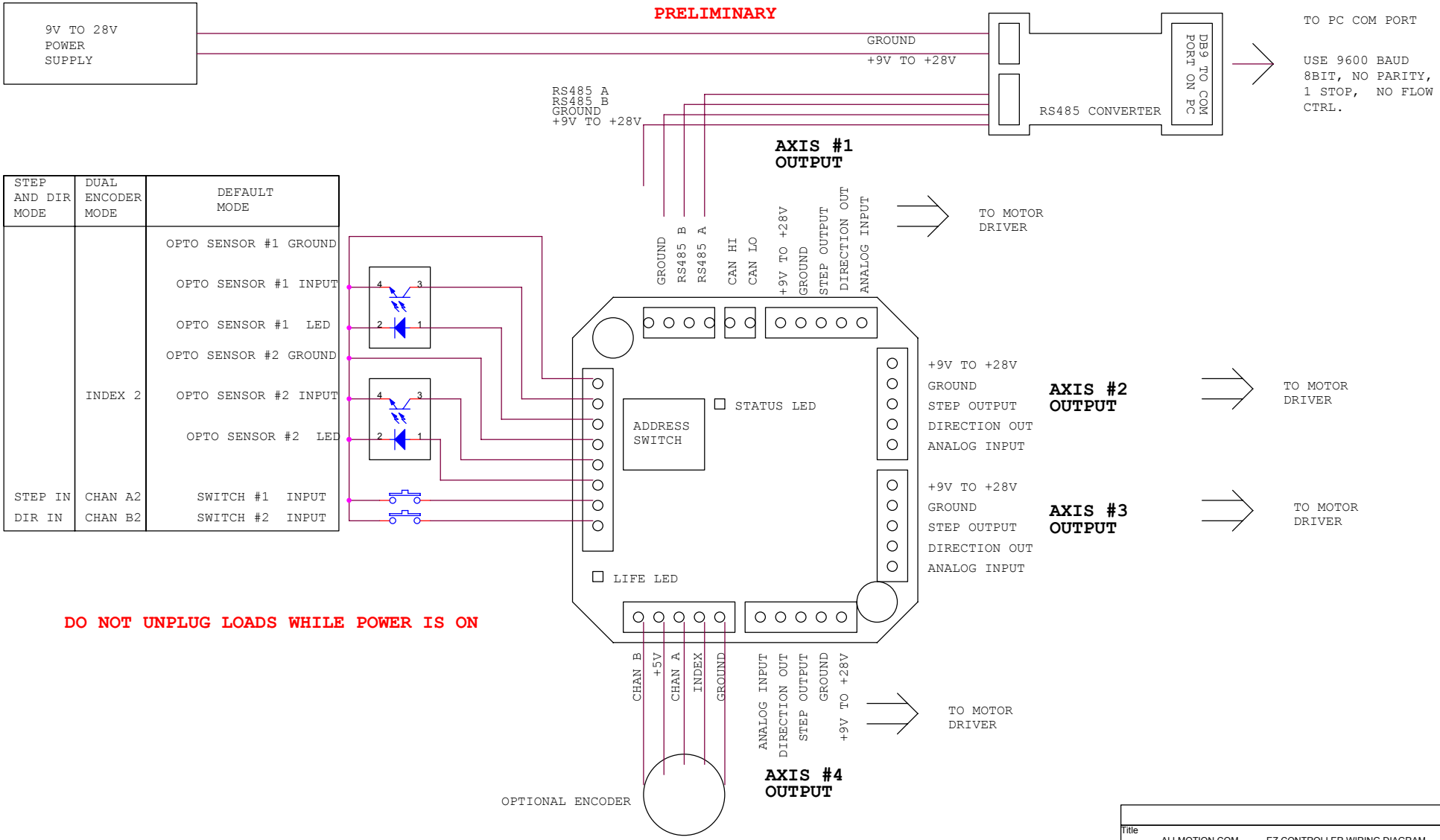

| STEP AND DIR MODE | DUAL ENCODER MODE | DEFAULT MODE |
|-------------------|-------------------|-----------------------|
| | | OPTO SENSOR #1 GROUND |
| | | OPTO SENSOR #1 INPUT |
| | | OPTO SENSOR #1 LED |
| | | OPTO SENSOR #2 GROUND |
| | INDEX 2 | OPTO SENSOR #2 INPUT |
| | | OPTO SENSOR #2 LED |
| STEP IN | CHAN A2 | SWITCH #1 INPUT |
| DIR IN | CHAN B2 | SWITCH #2 INPUT |

DO NOT UNPLUG LOADS WHILE POWER IS ON

PAGE DOWN FOR NEXT MODE

| | | |
|--|-----------------------------|--------------|
| Title | | |
| ALLMOTION.COM EZ CONTROLLER WIRING DIAGRAM | | |
| Size | Document Number | Rev |
| B | EZ CTRL WIRING | B6 |
| Date: | Saturday, December 13, 2008 | Sheet 2 of 7 |

EZCTRL17 WIRED AS 2 AXIS SERVO CONTROLLER

PRELIMINARY

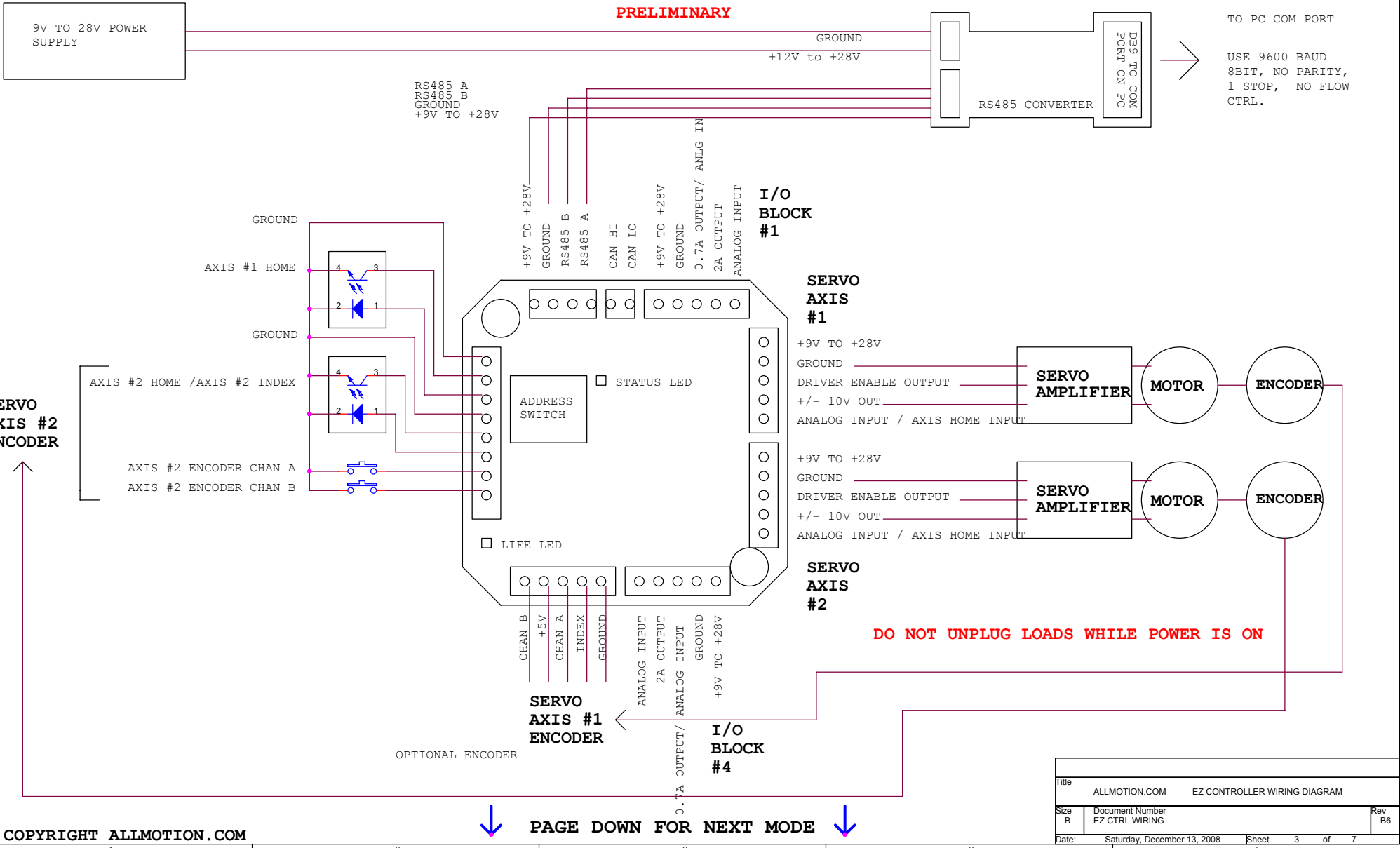

TO PC COM PORT
USE 9600 BAUD
8BIT, NO PARITY,
1 STOP, NO FLOW
CTRL.

DO NOT UNPLUG LOADS WHILE POWER IS ON

PAGE DOWN FOR NEXT MODE

| | | | |
|-------|-----------------------------|----------------|------------------------------|
| Title | | ALLMOTION.COM | EZ CONTROLLER WIRING DIAGRAM |
| Size | Document Number | EZ CTRL WIRING | |
| B | | Rev B6 | |
| Date: | Saturday, December 13, 2008 | Sheet | 3 of 7 |

EZCTRL17 WIRED AS GENERAL PURPOSE I/O BOARD

PRELIMINARY

9V TO 28V
POWER
SUPPLY

TO PC COM PORT

USE 9600 BAUD
8BIT, NO PARITY,
1 STOP, NO FLOW
CTRL.

| STEP AND DIR COUNTER | DUAL ENCODER MODE | MODE 0 |
|----------------------|-------------------|-----------------------|
| | | OPTO SENSOR #1 GROUND |
| | | OPTO SENSOR #1 INPUT |
| | | OPTO SENSOR #1 LED |
| | | OPTO SENSOR #2 GROUND |
| | INDEX 2 | OPTO SENSOR #2 INPUT |
| | | OPTO SENSOR #2 LED |
| STEP IN | CHAN A2 | SWITCH #1 INPUT |
| DIR IN | CHAN B2 | SWITCH #2 INPUT |

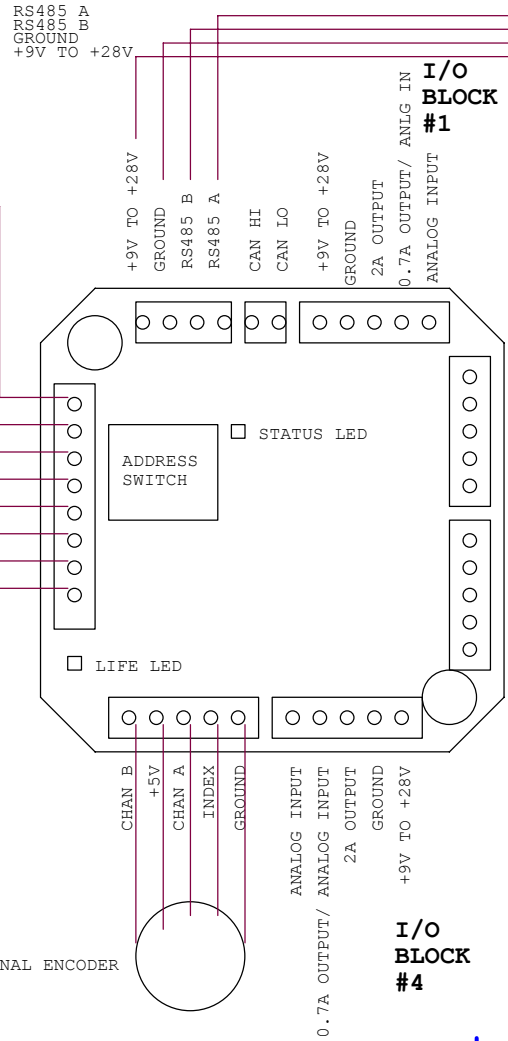

EXAMPLE I/O BLOCK 1 COMMANDS:
/1J10R TURNS OFF BOTH DRIVERS
/1J11R TURNS ON 0.7A OUTPUT
/1J13R TURNS BOTH OUTPUTS
/1?a1 READS BACK ANALOG INPUTS

I/O BLOCK #2

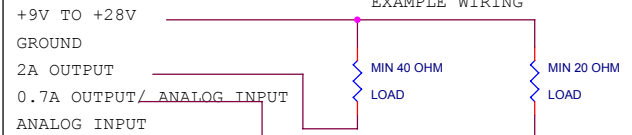

I/O BLOCK #3

+9V TO +28V
GROUND
2A OUTPUT
0.7A OUTPUT/ANALOG INPUT
ANALOG INPUT

NOTES:

- 1) ANALOG INPUTS ARE ACCURATE TO 7 BITS AS SOLD, HOWEVER THE RESOLUTION CAN BE IMPROVED TO 10 BITS BY REMOVING INPUT PROTECTION CIRCUITRY. PLEASE CONTACT THE FACTORY FOR DETAILS.
- 2) THE PIN THAT IS BOTH OUTPUT OR INPUT IS AN OUTPUT AS SOLD, BUT CAN BE CHANGED AT THE FACTORY TO BE AN INPUT.
- 3) OUTPUTS ARE OPEN COLLECTOR PULLDOWNS

DO NOT UNPLUG LOADS WHILE POWER IS ON

OPTIONAL ENCODER

PAGE DOWN FOR NEXT MODE

| | | | |
|-------|-----------------------------|----------------|------------------------------|
| Title | | ALLMOTION.COM | EZ CONTROLLER WIRING DIAGRAM |
| Size | Document Number | EZ CTRL WIRING | |
| B | | | |
| Date: | Saturday, December 13, 2008 | Sheet | 4 of 7 |
| | | | Rev B6 |

EZCTRL17 RC SERVO MODE

PRELIMINARY

9V TO 28V
POWER
SUPPLY

TO PC COM PORT

USE 9600 BAUD
8BIT, NO PARITY,
1 STOP, NO FLOW
CTRL.

| STEP AND DIR COUNTER | DUAL ENCODER MODE | MODE 0 |
|----------------------|-------------------|-----------------------|
| | | OPTO SENSOR #1 GROUND |
| | | OPTO SENSOR #1 INPUT |
| | | OPTO SENSOR #1 LED |
| | | OPTO SENSOR #2 GROUND |
| | INDEX 2 | OPTO SENSOR #2 INPUT |
| | | OPTO SENSOR #2 LED |
| STEP IN | CHAN A2 | SWITCH #1 INPUT |
| DIR IN | CHAN B2 | SWITCH #2 INPUT |

EXAMPLE RC COMMANDS
 CHANNEL ORDER: /1A(ONE), (TWO), (THREE), (FOUR)
 /1A100000,100000,100000,100000R APPROX SETS 2mS
 /1A-100000,-100000,-100000,-100000R APPROX SETS 1mS
 TYPICALLY USE V=ONE MILLION L=TEN THOUSAND
 /1V1000000,1000000,1000000,1000000R (ONE MILLION)
 /1L10000,10000,10000,10000R

PROGRAMMABLE PWM DRIVER
 USE LOWER CASE k COMMAND
 NUMBERS AFTER k SEPARATED BY COMMAS SET
 ON/OFF TIME IN INCREMENTS OF 50us

RS485 A
RS485 B
GROUND
+9V TO +28V

GROUND
+9V TO +28V

RS485 CONVERTER

DB9 TO COM
PORT ON PC

**I/O
BLOCK
#1**

GROUND
RS485 B
RS485 A
CAN HI
CAN LO
+9V TO +28V
GROUND
2A OUTPUT

**I/O
BLOCK
#2**

+9V TO +28V
GROUND
2A OUTPUT

+9V TO +28V
GROUND
2A OUTPUT

**I/O
BLOCK
#3**

2A OUTPUT
GROUND
+9V TO +28V

**I/O
BLOCK
#4**

RC SERVO CHANNEL 1

PROGRAMMABLE SLOW PWM /1k100,100R

RC SERVO CHANNEL 3

RC SERVO CHANNEL 4

DO NOT UNPLUG LOADS WHILE POWER IS ON

↓ **PAGE DOWN FOR NEXT MODE** ↓

| | | | |
|--------|-----------------------------|--|--------|
| Title | | ALLMOTION.COM EZ CONTROLLER WIRING DIAGRAM | |
| Size B | Document Number | EZ CTRL WIRING | |
| | | Rev | B6 |
| Date: | Saturday, December 13, 2008 | Sheet | 5 of 7 |

EZCTRL17 WIRED AS A HEATER CONTROLLER

PRELIMINARY

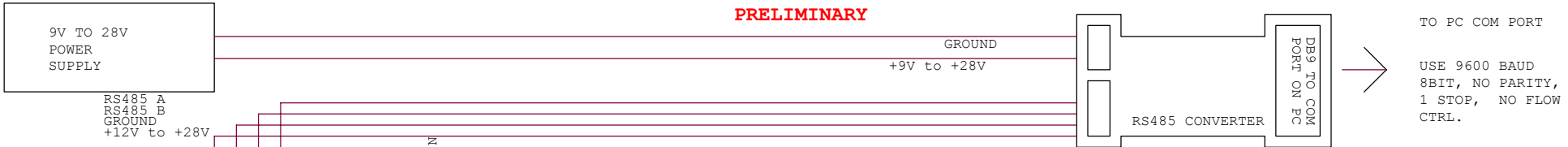

TO PC COM PORT
USE 9600 BAUD
8BIT, NO PARITY,
1 STOP, NO FLOW
CTRL.



TEMPERATURE CONTROL BLOCK #1

- NOTES:
- 1) USE 0.1C ACCURATE 10K AT 25C THERMISTOR FROM YSITEMPERATURE.COM . EG 44XXX SERIES
 - 2) THIS THERMISTOR IS INTERNALLY RATIOED AGAINST A 10K 0.1% RESISTOR
 - 3) COMPUTE THE MID POINT ADC READ VALUE ON A FULL SCALE OF 16384
 - 4) SET REGULATION VALUE FOR THE CHANNEL TO THIS VALUE.
 - 5) FOR HIGHER POWER USE AN EXTERNAL SOLID STATE RELAY
 - 6) PLACE THE THERMISTOR AS CLOSE AS POSSIBLE TO THE HEATING ELEMENT, TO MINIMIZE THE PHASE LAG IN THE CONTROL LOOP
 - 7) FOR SAFTY IN HIGH POWER APPLICATIONS THE USE OF A THERMAL FUSE IN SERIES WITH THE HEATER POWER IS STRONGLY RECOMMENDED
 - 8) ANALOG INPUTS ARE ACCURATE TO 8 BITS AS SOLD, HOWEVER THE RESOLUTION CAN BE IMPROVED TO 10+ BITS BY REMOVING INPUT PROTECTION CIRCUITRY. PLEASE CONTACT THE FACTORY FOR DETAILS.

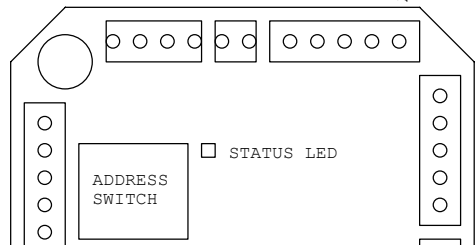

TEMPERATURE CONTROL BLOCK #2

+9V TO +28V
GROUND
2A OUTPUT
0.7A OUTPUT/ ANALOG IN
ANALOG INPUT

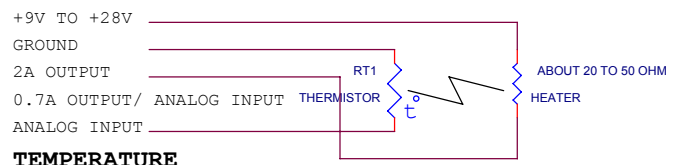

TEMPERATURE CONTROL BLOCK #3

DO NOT UNPLUG LOADS WHILE POWER IS ON

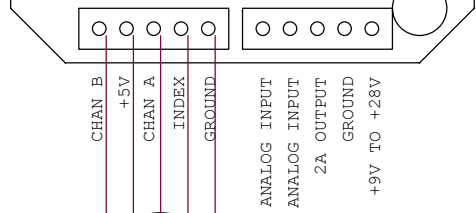

TEMPERATURE CONTROL BLOCK #4

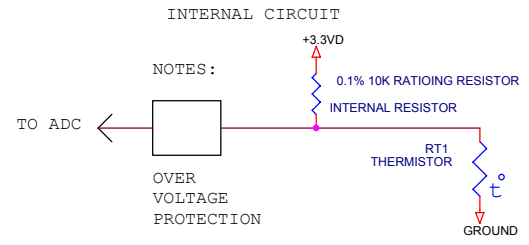

| | | |
|---------------|-----------------------------------|--------------|
| Title | | |
| ALLMOTION.COM | EZ CONTROLLER WIRING DIAGRAM | |
| Size B | Document Number EZ CTRL WIRING | Rev B6 |
| Date: | Saturday, December 13, 2008 | Sheet 6 of 7 |

EZCTRL ACCESSORIES AND OTHER ELECTRICAL NOTES

PRELIMINARY

MATING CONNECTORS:

- AMP MTA 100 SERIES
- 4PIN 22 GA, AMP PART 3-643813-4
- 8PIN 22 GA, AMP PART 3-643813-8
- 8PIN 26 GA, AMP PART 3-643814-8
- T HANDLE CRIMP TOOL DIGIKEY P/N A9982
- PISTOL GRIP TOOL DIGIKEY P/N A1998 + A2031

OPTO HOME SWITCH:

- 1) "Z" OR HOME COMMAND RUNS MOTOR UNTIL OPTO #1 IS ON FLAG EDGE.
- 2) AN OPTO SWITCH PROVIDED WITH EACH STARTER KIT
- 3) USE TRANSISTOR OPTO THAT HAS $I_c > 1mA$ @ $I_F = 20mA$.
- 4) EXAMPLES OF ACCEPTABLE OPTOS ARE:
 - DIGIKEY P/N QVA11134
 - DIGIKEY P/N H21A1
 - HONEYWELL HOA1887-012 (IS PREWIRED)
 - HONEYWELL HOA1870-33 (IS PREWIRED)
 - OPTEK OPB830W11 (IS PREWIRED)
- 5) THE OPTO COUPLER LED PIN HAS 200 OHM TO 5V IN SERIES ON THE BOARD. THE 150 OHM CAN BE REMOVED IF DESIRED FOR RUNNING SENSORS THAT REQUIRE DIRECT ACCESS TO 5V. THE COLLECTOR OF THE TRANSISTOR HAS A 10K PULLUP TO 5V.
- 6) ALL INPUTS ARE 3.3V MAX

SUITABLE POWER SUPPLIES:

- 1) FOR FIRST TIME USERS, TO GUARD AGAINST A POSSIBLE MISWIRE, A CURRENT LIMITED LAB SUPPLY SET TO 12V AND 0.5A IS RECOMMENDED.
- 2) A SUPPLY OF 24V AND 2A CAPABILITY IS GOOD FOR MOST PURPOSES. POSSIBLE CHOICES ARE:
 - DIGIKEY P/N 271-1112
 - DIGIKEY P/N Z1158 (ENCLOSED)

ON/OFF DRIVERS ALTERNATE WIRING DIAGRAM

- 1) ON/OFF DRIVERS RATED AT 0.7A / 2A AMPS.
- 2) THE NEGATIVE PIN OF THESE DRIVERS IS ACTUALLY AN OPEN COLLECTOR TYPE OUTPUT THAT PULLS DOWN TO GROUND. IT IS POSSIBLE TO DRIVE LOADS THAT ARE OF A DIFFERENT VOLTAGE THAN THE SUPPLY VOLTAGE, BY CONNECTING THE POSITIVE SIDE OF THE LOAD TO AN EXTERNAL SUPPLY, AND THE NEGATIVE SIDE TO THE -VE OUTPUT PIN. HOWEVER, IN CASE THIS IS DONE IT IS NECESSARY TO PLACE AN EXTERNAL "FREE WHEELING" DIODE ACROSS ANY INDUCTIVE LOADS. EXTERNAL SUPPLY VOLTAGE MUST BE LESS THAN SUPPLY VOLTAGE TO EZ STEPPER
- 3) EXTERNAL DIODE IS NOT NECESSARY IF BOTH SIDES OF LOAD ARE WIRED BACK TO THE EZ STEPPER.

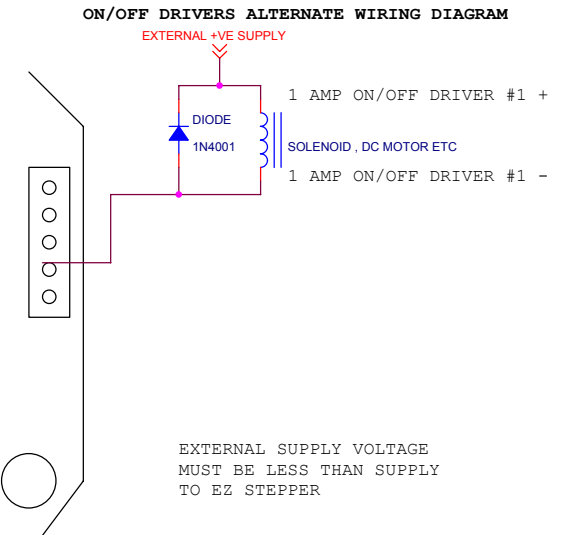

SEE NEXT PAGE FOR DIMENSIONAL INFO

COPYRIGHT ALLMOTION.COM

| | | |
|--|-----------------|--------|
| Title | | |
| ALLMOTION.COM EZ CONTROLLER WIRING DIAGRAM | | |
| Size | Document Number | Rev |
| B | EZ CTRL WIRING | B6 |
| Date: Saturday, December 13, 2008 | | |
| Sheet | | 7 of 7 |

PRELIMINARY

FEEDBACK POT1 GROUND
FEEDBACK POT1 WIPER
FEEDBACK POT1 POWER

POSITION COMMAND POT2 GROUND
POSITION COMMAND POT2 WIPER
POSITION COMMAND POT2 POWER

SWITCH #1 CLOSURE TO GROUND INPUT
SWITCH #2 CLOSURE TO GROUND INPUT

SIMPLE CIRCUIT,
7 BIT ACCURACY

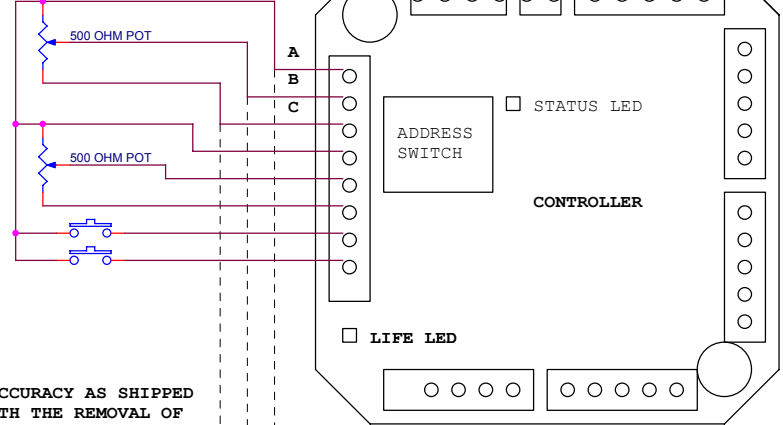

NOTES:

- 1) ALL 4 INPUTS ARE ANALOG INPUTS
- 2) ADC's VALUES RANGE FROM 0-16368. THE ACCURACY AS SHIPPED IS 7 BIT BUT CAN BE IMPROVED TO >10BIT WITH THE REMOVAL OF THE INPUT PROTECTION CIRCUITRY, CONTACT FACTORY FOR DETAILS
- 3) POTS IN THE RANGE OF 500 OHM - 10K ARE SUGGESTED, LOWER VALUES ARE LESS AFFECTED BY INTERNAL 10K PULLUP. 500 OHM RECOMMENDED.
- 4) IF USING POT FOR POSITION FEED BACK WITH /1N3R MODE, IF MOTOR EXHIBITS POSITIVE FEEDBACK, SWITCH ENDS OF POT
- 5) 10K INTERNAL PULLUP WILL INTERFERE WITH LINEARITY OF POT VOLTAGE, AND MAY NEED TO BE REMOVED - CONTACT FACTORY.
- 6) INPUT OVERVOLTAGE PROTECTION CIRCUITRY MAY NEED TO BE REMOVED FOR >7BIT ACCURACY - CONTACT FACTORY.

CIRCUITS INTERNAL TO DRIVE

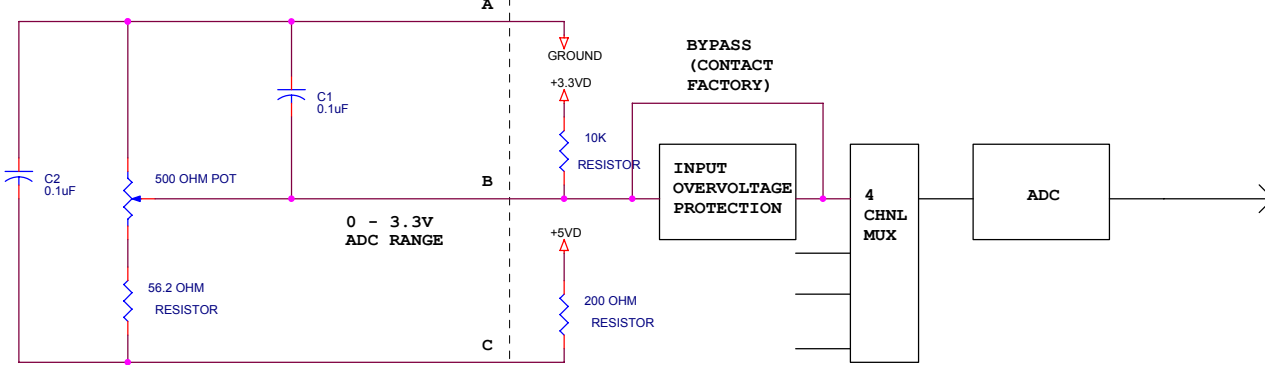

ENHANCED EXTERNAL CIRCUIT FOR > 10BIT ACCURACY

WIRING DIAGRAM ANALOG INPUT OR POTENTIOMETER FEEDBACK

| | | | |
|-------|-----------------------------|--|--------|
| Title | | ALLMOTION.COM EZ CONTROLLER WIRING DIAGRAM | |
| Size | Document Number | Rev | |
| B | EZ CTRL WIRING | B6 | |
| Date: | Saturday, December 13, 2008 | Sheet | 8 of 7 |

COPYRIGHT ALLMOTION.COM

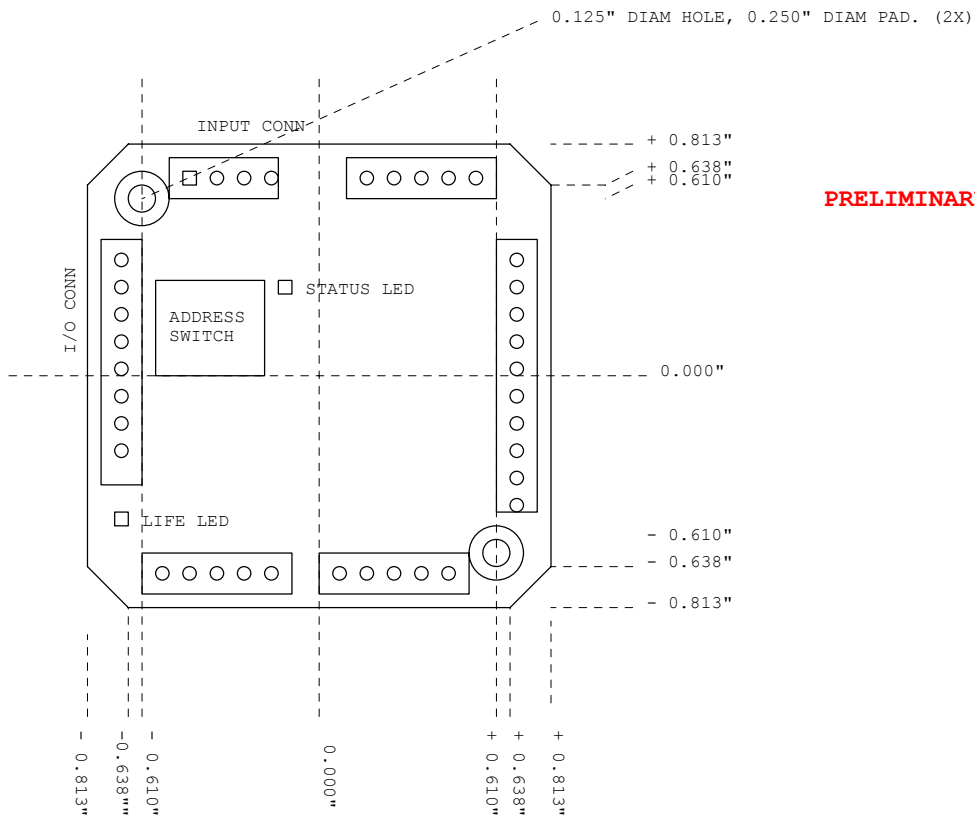

PRELIMINARY

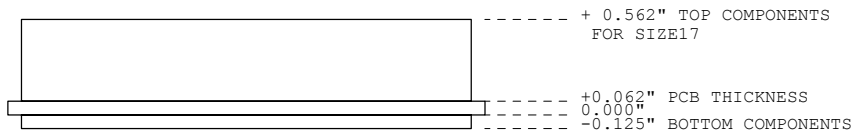

DESIGN USES THE NEMA 17 SIZE STANDARD 1.22" SQUARE BOLT PATTERN

EZCTRL DIMENSIONAL INFORMATION

COPYRIGHT ALLMOTION.COM

| | | |
|--|-----------------------------|--------------|
| Title | | |
| ALLMOTION.COM EZ CTRL DIMENSIONAL INFO | | |
| Size | Document Number | Rev |
| B | EZCTRL | B6 |
| Date: | Saturday, December 13, 2008 | Sheet 9 of 7 |