

- HALL A
- HALL B
- HALL C
- +5V HALL SENSOR POWER
- HALL SENSOR GROUND
- PHASE A POWER DRIVER
- PHASE B POWER DRIVER
- PHASE C POWER DRIVER

NOTES:

- 1) IF MOTOR EXHIBITS POSITIVE FEEDBACK, SWITCH MOTOR POWER LEADS. OR SWITCH ENCODER A, B LINES
- 2) KEEP ENCODER / INPUTS AWAY FROM NOISEY MOTOR POWER WIRES.

DO NOT UNPLUG LOADS WHILE POWER IS ON. BREAKING OF CURRENT IN THE INDUCTANCE OF THE MOTOR GENERATES A HIGH VOLTAGE ARC, WHICH DAMAGES THE DRIVE.

SEE PAGE 4 FOR MANUFACTURER SPECIFIC BLDC MOTOR WIRING EXAMPLES

↓ PAGE DOWN ↓

COPYRIGHT ALLMOTION.COM

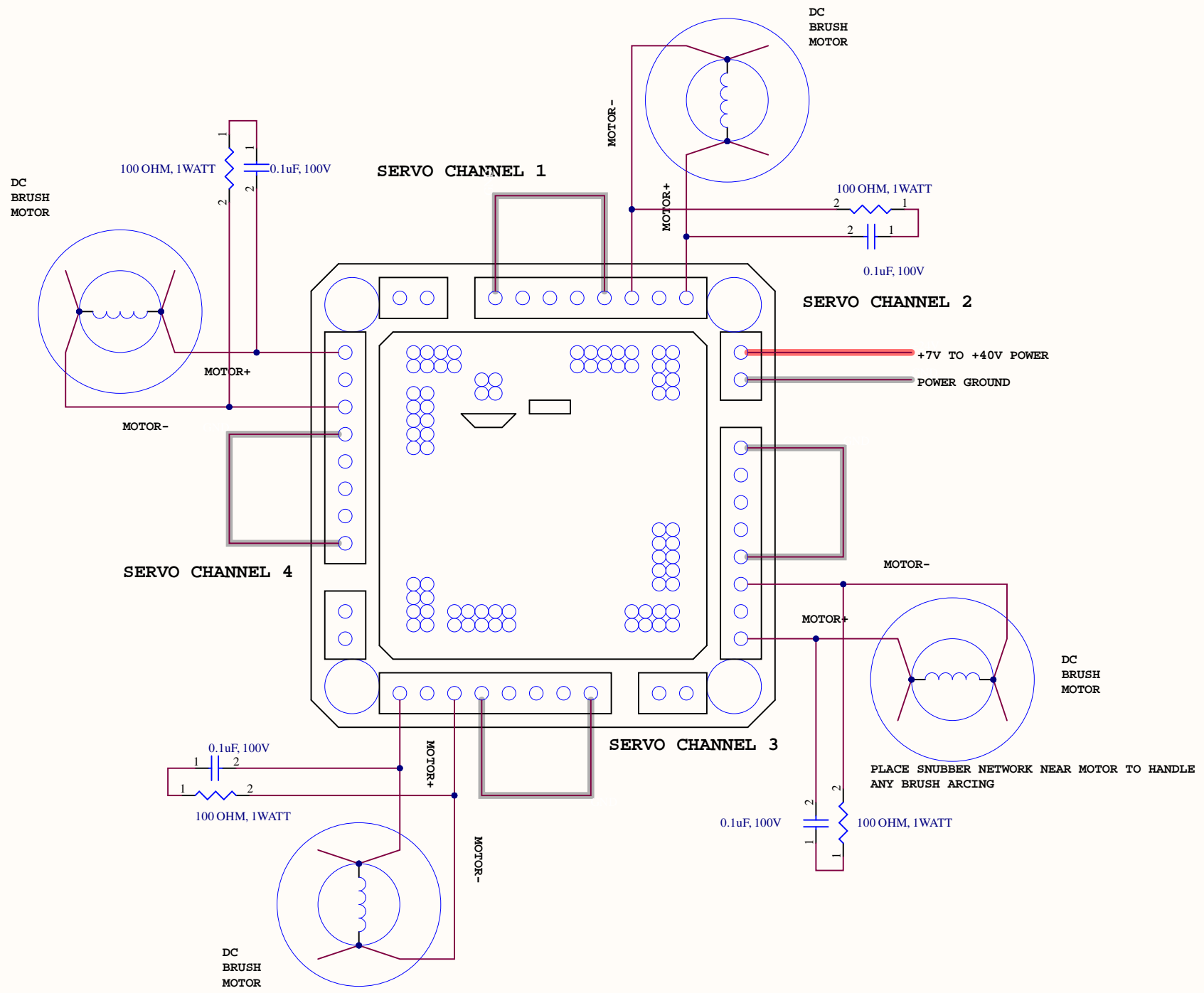

DO NOT UNPLUG LOADS WHILE
POWER IS ON. BREAKING OF
CURRENT IN THE INDUCTANCE OF
THE MOTOR GENERATES A HIGH
VOLTAGE ARC, WHICH DAMAGES
THE DRIVE.

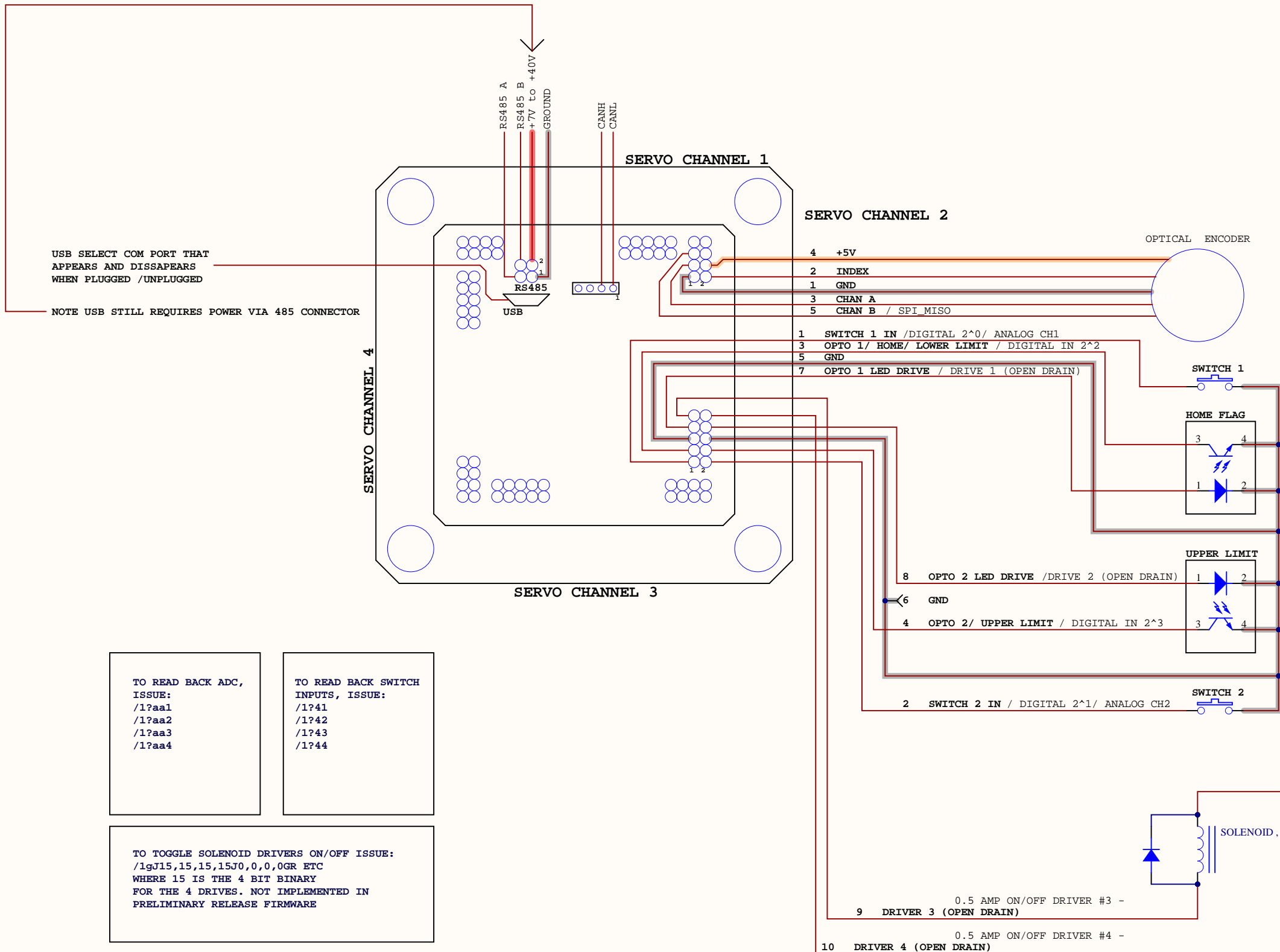

USB SELECT COM PORT THAT APPEARS AND DISSAPEARS WHEN PLUGGED /UNPLUGGED

NOTE USB STILL REQUIRES POWER VIA 485 CONNECTOR

ENCODER CONNECTOR PINOUT

- 1 GND
- 2 INDEX
- 3 CHAN A
- 4 +5V
- 5 CHAN B / SPI_MISO
- 6 SPI_MOSI
- 7 SPI_CLK
- 8 SPI_CS2

I/O CONNECTOR PINOUT

- 1 SWITCH 1 IN/DIGITAL 2^0/ ANALOG CH1
- 2 SWITCH 2 IN/DIGITAL 2^1/ ANALOG CH2
- 3 OPTO 1/ HOME/ LOWER LIMIT/ DIGITAL IN 2^2
- 4 OPTO 2/ UPPER LIMIT/ DIGITAL IN 2^3
- 5 GND
- 6 GND
- 7 OPTO 1 LED DRIVE/ DRIVE 1 (OPEN DRAIN)
- 8 OPTO 2 LED DRIVE/ DRIVE 2 (OPEN DRAIN)
- 9 DRIVER 3 (OPEN DRAIN)
- 10 DRIVER 4 (OPEN DRAIN)

TO READ BACK ADC, ISSUE:
/1?aa1
/1?aa2
/1?aa3
/1?aa4

TO READ BACK SWITCH INPUTS, ISSUE:
/1?41
/1?42
/1?43
/1?44

TO TOGGLE SOLENOID DRIVERS ON/OFF ISSUE:
/1gJ15,15,15,15J0,0,0,0GR ETC
WHERE 15 IS THE 4 BIT BINARY FOR THE 4 DRIVES. NOT IMPLEMENTED IN PRELIMINARY RELEASE FIRMWARE

SERVO CHANNEL 2

- 4 +5V
- 2 INDEX
- 1 GND
- 3 CHAN A
- 5 CHAN B / SPI_MISO

- 1 SWITCH 1 IN /DIGITAL 2^0/ ANALOG CH1
- 3 OPTO 1/ HOME/ LOWER LIMIT / DIGITAL IN 2^2
- 5 GND
- 7 OPTO 1 LED DRIVE / DRIVE 1 (OPEN DRAIN)

- 8 OPTO 2 LED DRIVE /DRIVE 2 (OPEN DRAIN)
- 6 GND
- 4 OPTO 2/ UPPER LIMIT / DIGITAL IN 2^3

- 2 SWITCH 2 IN / DIGITAL 2^1/ ANALOG CH2

- 9 DRIVER 3 (OPEN DRAIN) - 0.5 AMP ON/OFF DRIVER #3 -
- 10 DRIVER 4 (OPEN DRAIN) - 0.5 AMP ON/OFF DRIVER #4 -

I/O WIRING		A13	
EZ QUAD SERVO			
Wiring Diagram			
Print Date:	7/11/2023 10:54:05 AM	Sheet	3 of 8

AUXILIARY ENCODER CONNECTOR PINOUT

- 1 GND
- 2 INDEX
- 3 CHAN A
- 4 +5V
- 5 CHAN B
- 6 STROBE

AUXILIARY ENCODER 1

- CHANNEL B 5
- CHANNEL A 3
- GND 1
- INDEX 2
- +5V 4
- STROBE 6

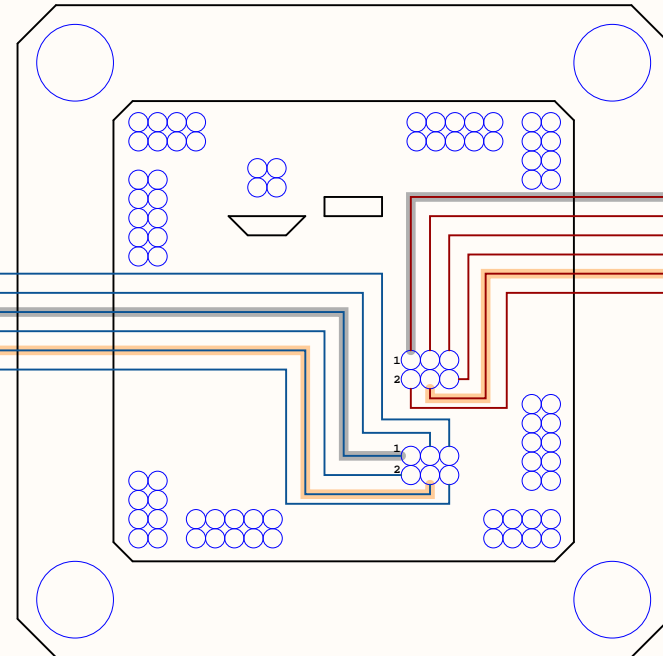

AUXILIARY ENCODER 2

- 1 GND
- 3 CANNEL A
- 5 CANNEL B
- 6 STROBE
- 4 +5V
- 2 INDEX

NOTE: MOTORS WITHOUT ENCODERS CAN BE RUN IN THE "N0" VELOCITY MODE, OR FOR FINER CONTROL THEY CAN BE RUN IN "N1" MODE WITH TWO OF THE HALL SENSOR LINES WIRED TO THE ENCODER CHANNELS A AND B TO ACT AS A ROUGH POSITION ENCODER. THIS WILL ALLOW FINE ACCELERATION CONTROL, OR ROUGH POSITION CONTROL. THE VELOCITY WILL NEED TO BE SET LOW. TRY /1L1V1000R, ENSURE THAT THE ENCODER IS HOOKED UP TO COUNT UP WHEN THE MOTOR MOVES IN THE POSITIVE DIRECTION.

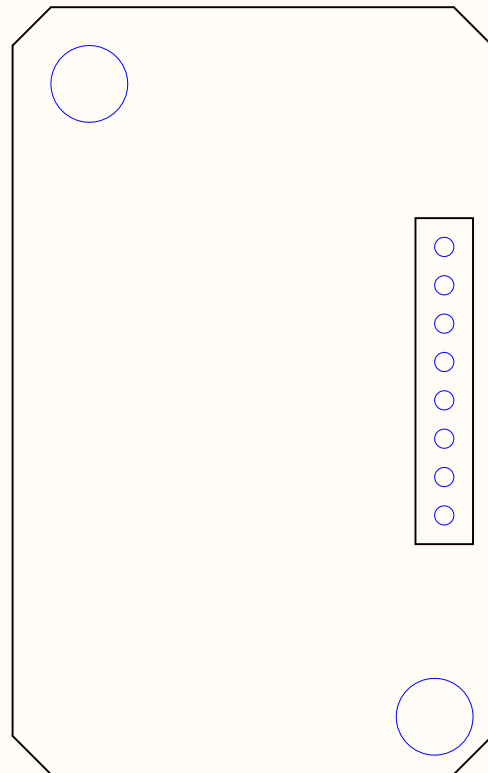

	POPULAR MANUFACTURER WIRE COLORS									
	PITTMAN	MAXON	MAXON	ELECTROCRAFT OPTICAL HALL	ELCTROCRAFT MAGNETIC HALL	FAULHARBER	ANAHEIM AUTOMATA	HARMONIC DRIVES RSF8B	PORTESCAP NUVODISC 32BF	MAXON EC-max
HALL A	WHITE	BLUE	RED/GREY	BROWN	YELLOW	GREEN	WHITE	YELLOW	SENSOR1	GREY
HALL B	GREY	GREY	WHITE/GREY	WHITE	GREEN	BLUE	BLUE	BROWN	SENSOR3	BROWN
HALL C	BLUE	VIOLET	BLACK/GREY	GREEN	GREY	GREY	GREEN	RED	SENSOR2	YELLOW
+5V HALL SENSOR POWER	PURPLE	YELLOW	GREEN	NC	ORANGE	RED	RED	WHITE (PINK)	VDD	GREEN
HALL SENSOR GROUND	BLACK	GREEN	BLUE	NC	BLACK	BLACK	BLACK	BLACK	GROUND	BLUE
PHASE A POWER DRIVER	BROWN	ORANGE	WHITE	BROWN	FROM OPTICAL ENCODER	BROWN	BLACK (M)	BLACK (M)	PHASE 3	BLACK
PHASE B POWER DRIVER	RED	RED	BLACK	WHITE	+	WHITE	YELLOW (M)	RED (M)	PHASE 2	RED
PHASE C POWER DRIVER	ORANGE	BROWN	RED	BLUE	HALL	BLUE	YELLOW	RED (M)	PHASE 1	WHITE
				GROUND	BLACK				DO NOT CONNECT	ORANGE BLUE GREEN
				INDEX	ORANGE					
				CHAN A	YELLOW					
				+5V	RED					
				CHAN B	BLUE					

NOTE: ENCODER SIGNALS MUST BE >4.5V HIGH LEVEL. THIS MAY REQUIRE EXTERNAL PULLUPS.

PLEASE NOTE: FOR OTHER MOTORS, ALLMOTION WILL BE PLEASED TO WORK OUT THE WIRING FOR NO CHARGE.

BLDC MOTOR WIRING BY MANUFACTURER		
EZ QUAD SERVO	A13	
Wiring Diagram		
Print Date: 7/11/2023 10:54:05 AM	Sheet 5 of 8	6

NOTE: MOTORS WITHOUT ENCODERS CAN BE RUN IN THE "N0" VELOCITY MODE, OR FOR FINER CONTROL THEY CAN BE RUN IN "N1" MODE WITH TWO OF THE HALL SENSOR LINES WIRED TO THE ENCODER CHANNELS A AND B TO ACT AS A ROUGH POSITION ENCODER. THIS WILL ALLOW FINE ACCELERATION CONTROL, OR ROUGH POSITION CONTROL. THE VELOCITY WILL NEED TO BE SET LOW. TRY /11LV1000R, ENSURE THAT THE ENCODER IS HOOKED UP TO COUNT UP WHEN THE MOTOR MOVES IN THE POSITIVE DIRECTION.

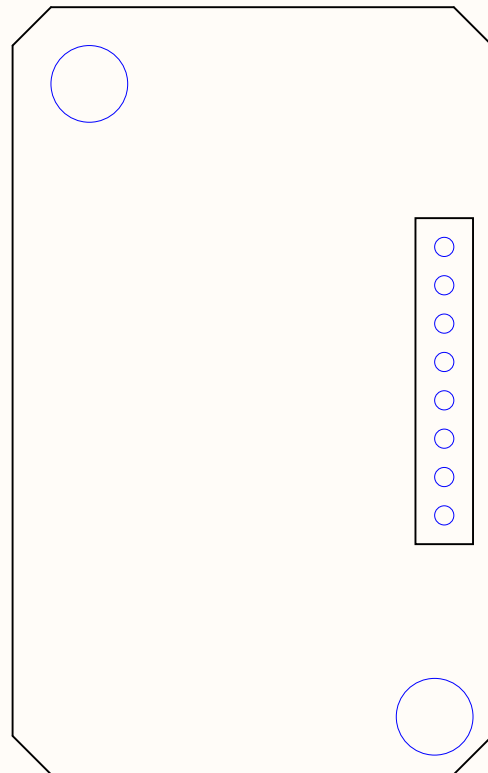

ADDITIONAL POPULAR MANUFACTURER WIRE COLORS

				KOLLMORGEN AKM11E- BNMN2-00						
HALL A				BROWN						
HALL B				GREY						
HALL C				WHITE						
+5V HALL SENSOR POWER				NC						
HALL SENSOR GROUND				NC / SHIELD						
PHASE A POWER DRIVER				BLUE						
PHASE B POWER DRIVER				BROWN						
PHASE C POWER DRIVER				VIOLET						

TO ENCODER	
GROUND	BLACK
INDEX	VIOLET
CHAN A	GREEN
+5V	RED
CHAN B	BLUE

NOTE: ENCODER SIGNALS MUST BE >4.5V HIGH LEVEL. THIS MAY REQUIRE EXTERNAL PULLUPS.

PLEASE NOTE: FOR OTHER MOTORS, ALLMOTION WILL BE PLEASED TO WORK OUT THE WIRING FOR NO CHARGE.

PRELIMINARY RELEASE
EZ-QUAD-SERVO
WIRING DIAGRAM

ADDITIONAL MANUFACTURER BLDC MOTOR WIRING	
EZ QUAD SERVO	A13
Wiring Diagram	
Print Date: 7/11/2023 10:54:05 AM	Sheet 6 of 8



EZSV23 ACCESSORIES AND OTHER ELECTRICAL NOTES

MATING CONNECTORS:

POWER CONNECTIONS AMP MTA 100 SERIES

8PIN 22 GA DIGIKEY P/N A31111 (NEMA23 MOTOR)

8PIN 24 GA DIGIKEY P/N A31023 (NEMA17 MOTOR)

8PIN 26 GA DIGIKEY P/N A31030

T HANDLE CRIMP TOOL DIGIKEY P/N A9982

PISTOL GRIP TOOL DIGIKEY P/N A1998 + A2031

SIGNAL CONNECTIONS HIROSE DF11 SERIES

4PIN DF11-4DS-2C

8PIN DF11-8DS-2C

10PIN DF11-10DS-2C

USB: USB MICRO

OPTO HOME SWITCH:

1) "Z" OR HOME COMMAND RUNS MOTOR UNTIL OPTO #1 IS ON FLAG EDGE.

2) AN OPTO SWITCH PROVIDED WITH EACH STARTER KIT

3) USE TRANSISTOR OPTO THAT HAS $I_c > 1mA$ @ $I_F = 20mA$.

4) EXAMPLES OF ACCEPTABLE OPTOS ARE:

DIGIKEY P/N QVA11134

DIGIKEY P/N H21A1

HONEYWELL HOA1887-012 (IS PREWIRED)

HONEYWELL HOA1870-33 (IS PREWIRED)

OPTEK OPB830W11 (IS PREWIRED)

5) THE OPTO COUPLER LED PIN HAS 200 OHM TO 5V IN SERIES ON THE BOARD. THE 200 OHM CAN BE REMOVED IF DESIRED FOR RUNNING SENSORS THAT REQUIRE DIRECT ACCESS TO 5V. (OR USE ENCODER 5V POWER) THE COLLECTOR OF THE TRANSISTOR HAS A 10K PULLUP TO 5V. THE TOTAL CURRENT DRAWN FROM THE 5V SUPPLY (INCLUDING OPTOS) MUST BE LESS THAN 200mA.

6) ALL INPUTS ARE 0-3.3V ADC INPUTS, THE ONE/ZERO THRESHOLD IS FACTORY SET TO 1.23V, TO BE TTL COMPATIBLE, AND CAN BE CHANGED BY SOFTWARE COMMAND.

ENCODERLESS OPERATION:

1) THE EZSERVO CAN PERFORM VELOCITY MODE CONTROL OF A MOTOR THAT DOES NOT HAVE AN ENCODER BY USING THE HALL SENSORS AS A GAGE OF SPEED. (N=0 MODE)

2) IT IS POSSIBLE TO USE THE N=1 POSITION CONTROL MODE BY WIRING TWO OF THE HALL SENSOR LINES TO THE ENCODER A AND B INPUTS IN ADDITION. THIS ALLOWS A CRUDE POSITION CONTROL MODE. IN THIS MODE THE VELOCITY CONTROL IS SUPERIOR TO THE N=0 MODE. USE SMALL ACCELERATIONS AND VELOCITIES IN THIS MODE. Eg TRY /1L1V10000P0R

3) THE RESPONSE CAN ALSO BE "STIFFENED" BY INCREASING THE PID GAIN CONSTANTS eg /1L10w3000y3000V10000P0R

4) IF WIRING HALL SENSORS AS ENCODERS, USE THE ENCODER 5 V TO POWER THE HALL SENSORS.

MOTORS:

1) THE EZ SERVO WILL DRIVE MOST SERVO MOTORS

2) FOR BEST PERFORMANCE SELECT A MOTOR THAT HAS A BACK EMF OF ABOUT 1/2 OF THE SUPPLY VOLTAGE, AT THE MAX SPEED DESIRED TO RUN AT. (Eg USE A 12V MOTOR WITH A 24V SUPPLY).

3) TYPICALLY A MOTOR THAT HAS AN INDUCTANCE OF AROUND 1mH AND A RESISTANCE OF AROUND 1 OHM WORKS WELL. BUT OTHER VALUES ARE ALSO OK. (0.1mH MINIMUM)

ON/OFF DRIVERS ALTERNATE WIRING DIAGRAM

1) ON/OFF DRIVERS RATED AT 2 AMPS PEAK, 1 AMP CONTINUOUS.

2) THE NEGATIVE PIN OF THESE DRIVERS IS ACTUALLY AN OPEN COLLECTOR TYPE OUTPUT THAT PULLS DOWN TO GROUND. IT IS POSSIBLE TO DRIVE LOADS THAT ARE OF A DIFFERENT VOLTAGE THAN THE SUPPLY VOLTAGE, BY CONNECTING THE POSITIVE SIDE OF THE LOAD TO AN EXTERNAL SUPPLY, AND THE NEGATIVE SIDE TO THE -VE OUTPUT PIN. HOWEVER, IN CASE THIS IS DONE IT IS NECESSARY TO PLACE AN EXTERNAL "FREE WHEELING" DIODE ACROSS ANY INDUCTIVE LOADS. EXTERNAL SUPPLY VOLTAGE MUST BE LESS THAN SUPPLY VOLTAGE TO EZ STEPPER

3) EXTERNAL DIODE IS NOT NECESSARY IF BOTH SIDES OF LOAD ARE WIRED BACK TO THE EZ STEPPER.

USE OF HALL SENSORS AS ENCODERS

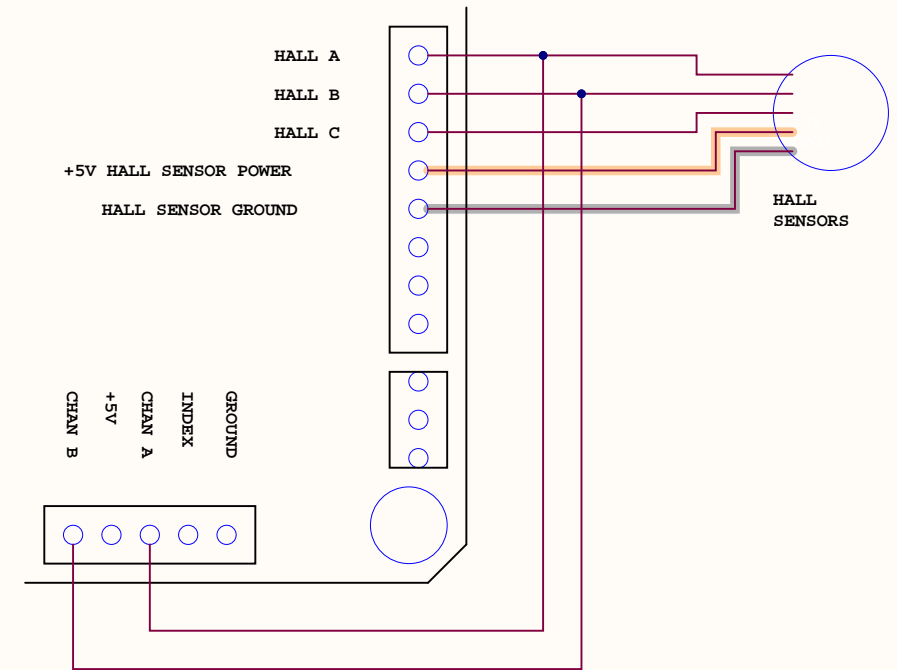

ON/OFF DRIVERS ALTERNATE WIRING DIAGRAM

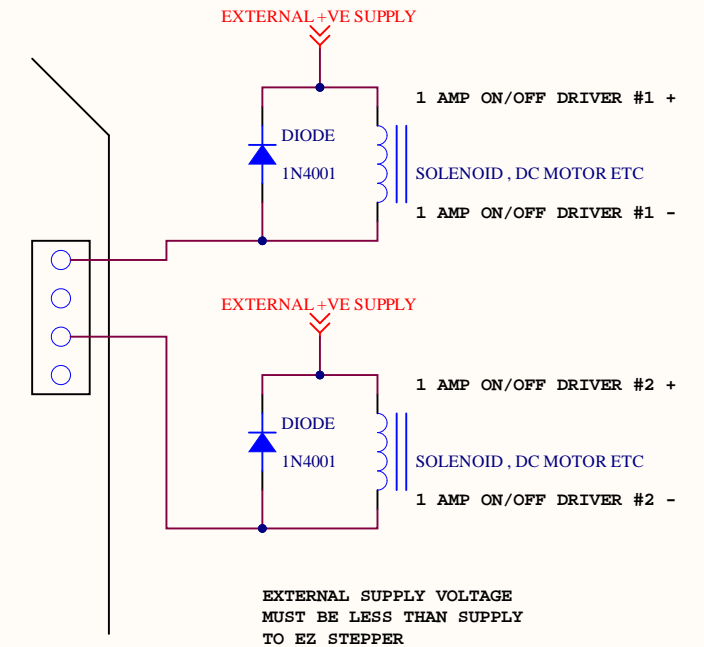

SEE NEXT PAGE FOR DIMENSIONAL INFO

COPYRIGHT ALLMOTION.COM

ADDITIONAL INFORMATION		A13	MOTION
EZ QUAD SERVO			
Wiring Diagram			
Print Date:	7/11/2023 10:54:05 AM	Sheet 7 of 8	6

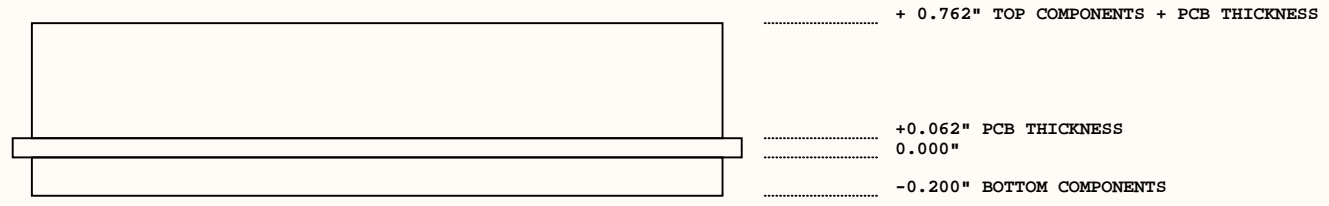
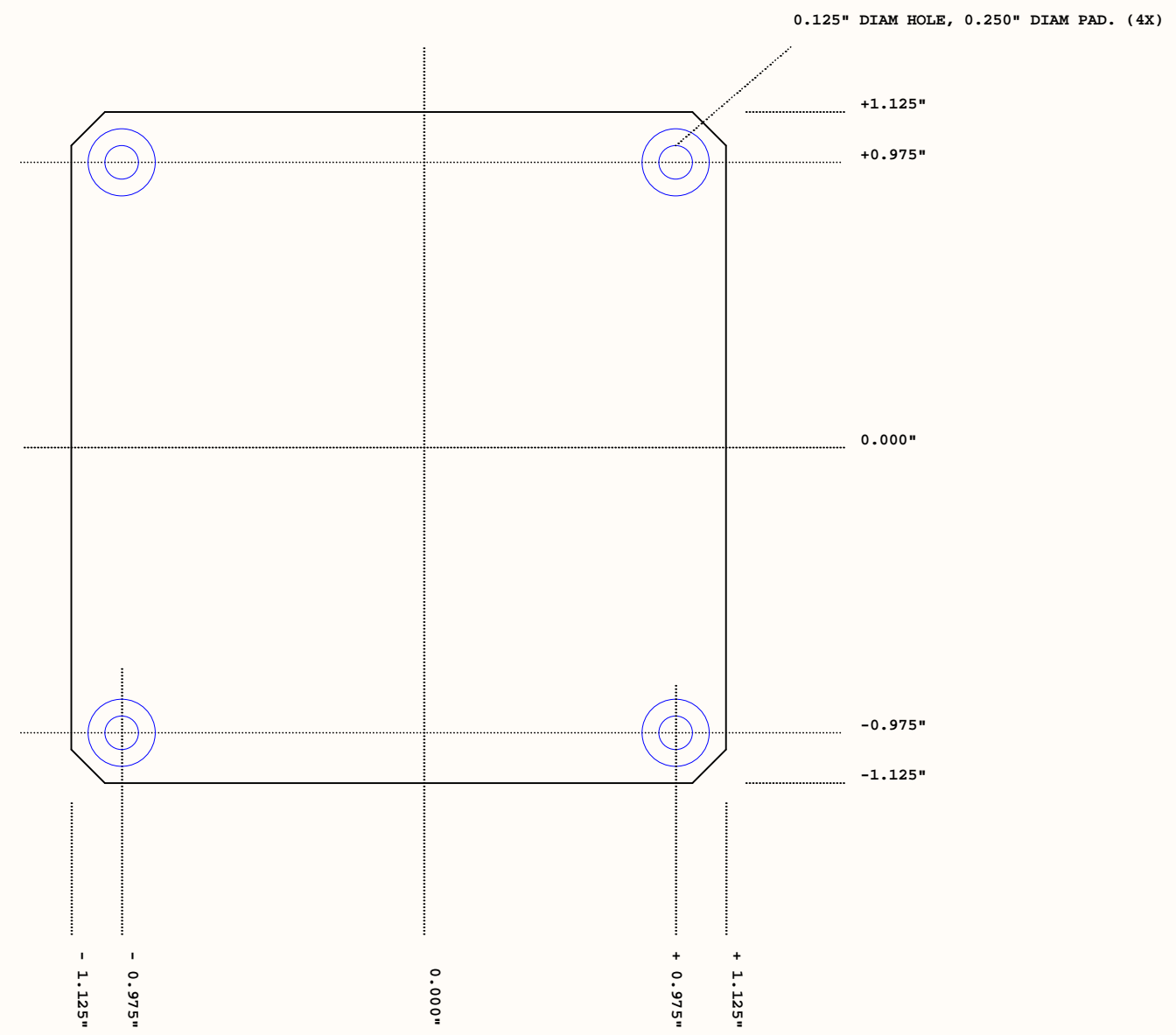

<i>DIMENSIONS</i>		A13	MOTION
<i>EZ QUAD SERVO</i>			
<i>Wiring Diagram</i>			
Print Date: 7/11/2023 10:54:05 AM	Sheet 8 of 8		